

LIGHTNIN[®]

98 Series Mixers

Geared for the long run.



20 to 175 HP units are available in a full range of standard AGMA speeds from 20 to 100 rpm.

Compact drive design requires significantly less oil for lubrication – eliminates need for large oil sump.

Integral mounting plate eliminates the need for an additional bolted plate. Permits mounting on large threaded rods which facilitates adjustments when liquid-level sensitive impellers are used.

Optional seal cartridge can be removed easily in four simple steps without having to move the gear drive or motor, and without having to loosen any mixer shaft bearings.

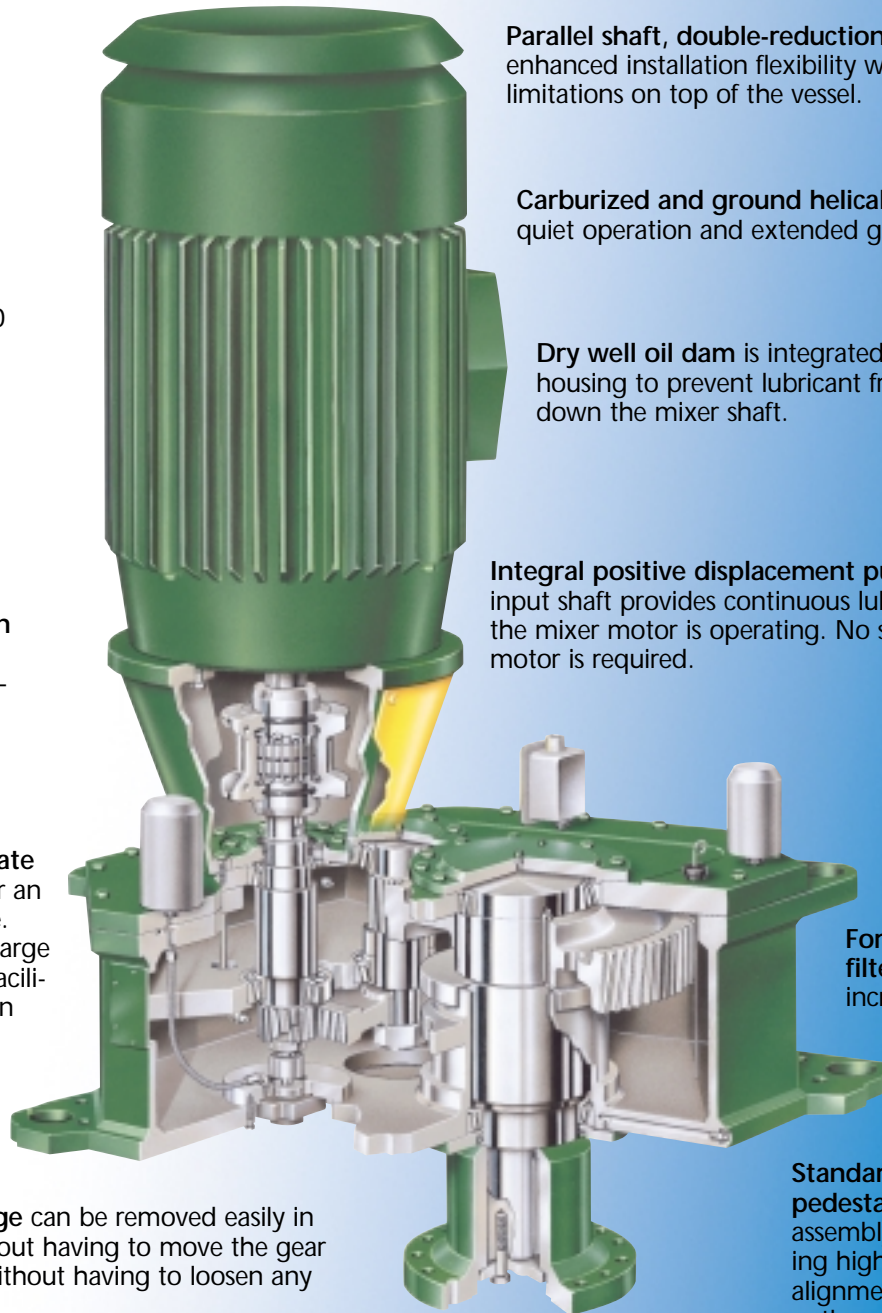

Parallel shaft, double-reduction design provides enhanced installation flexibility where there are space limitations on top of the vessel.

Carburized and ground helical gearing helps ensure quiet operation and extended gear life.

Dry well oil dam is integrated into the gear housing to prevent lubricant from leaking down the mixer shaft.

Integral positive displacement pump driven off the input shaft provides continuous lubrication whenever the mixer motor is operating. No separate lubrication motor is required.

Forced lubrication system filters any contaminants to increase oil life.

Standard C-face motor and pedestal mount reduces assembly time while eliminating high-speed coupling alignment and the need for outboard motor support.

YOU AND LIGHTNIN. THE RIGHT MIX.

LIGHTNIN

LIGHTNIN® 98 Series Mixers. The right fit.

Optional seal unit features exclusive *LIGHTNIN* IsoLoad design for longer gear life.

Traditionally, internal gear drive components are subject to large axial and bending loads which are the primary source of unwanted gear deflection and misalignment. Left unchecked, these dynamic loads can significantly reduce gear life or cause sudden gear-drive failure. (These loads are attributed to the fluid forces which are applied perpendicular to the mixer shaft at the impellers.)

The solution. *LIGHTNIN*'s IsoLoad feature isolates the gearing from the effects of these fluid forces through the following combination of design advantages:

- A strategically positioned bronze bushing – acting as a radial bearing – transfers reaction force loads into the upper quill shaft bearing.
- The lower quill shaft bearing experiences no external loading and does not support the mixer shaft in any way.
- Clearance between the mixer shaft and quill shaft ensures that no bending loads are imposed on the quill shaft, effectively isolating the gearing from the mechanical effects created by the fluid forces.
- The fixed bearing located below the gear drive in the seal cartridge absorbs radial reaction forces in addition to the axial loads. As a result, they are prevented from being transferred to the gear drive.
- The precise positioning of the fixed bearing within millimeters of the mixer seal faces minimizes shaft runout and dynamic deflection to maximize seal life.

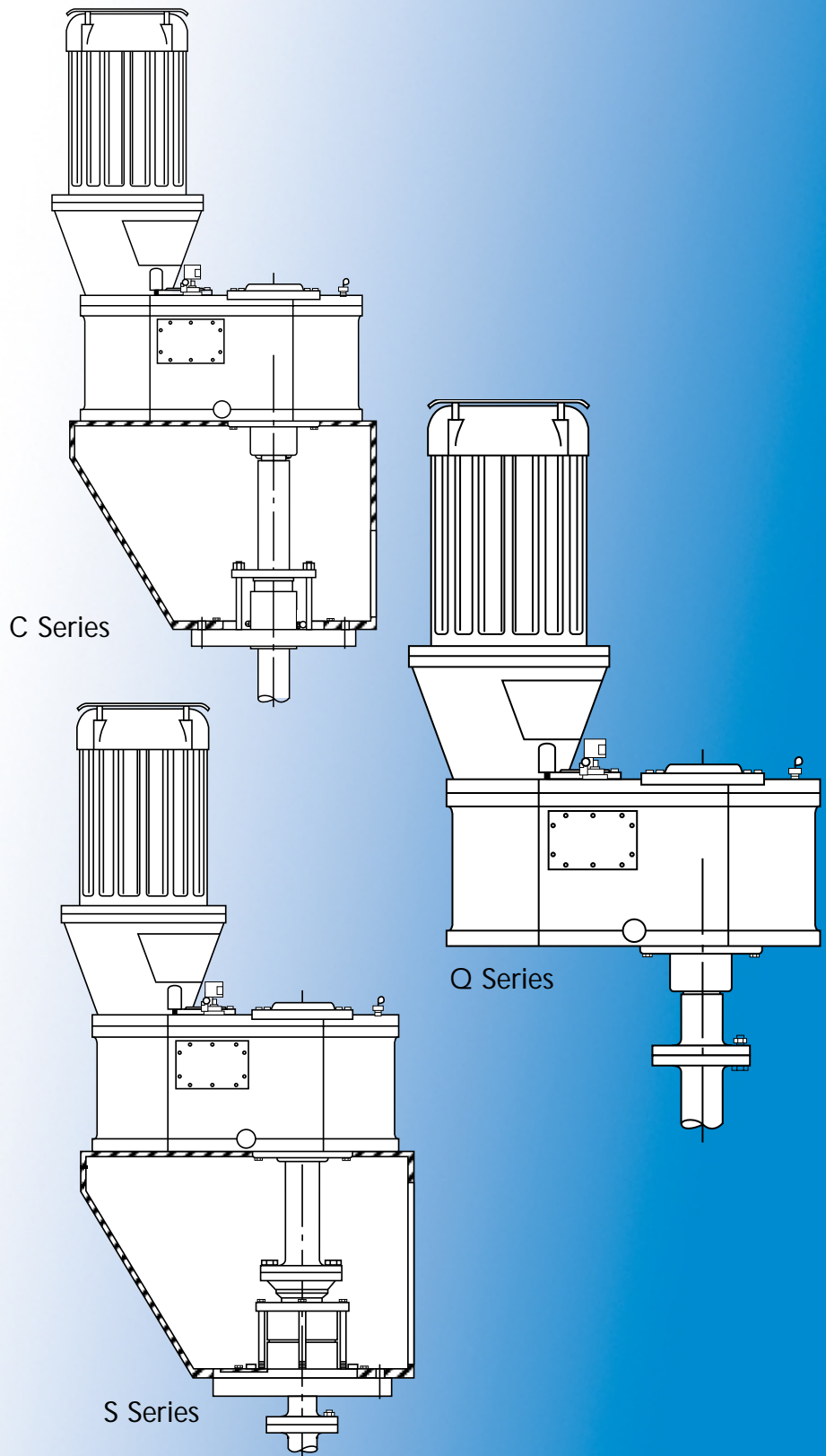

135 Mt. Read Blvd., P.O. Box 1370, Rochester, New York 14603
Telephone: 716-436-5550 Fax: 716-436-5589
Internet Address: <http://www.LIGHTNIN-MIXERS.COM>

Members of the *LIGHTNIN* group are located in the following cities:
Rochester, NY, USA • Toronto, Canada • Poynton, England • Jurong, Singapore • Sydney,
Australia • Milan, Italy • Shanghai, China • Rio de Janeiro, Brazil • Johannesburg, South Africa



A UNIT OF GENERAL SIGNAL 

LIGHTNIN