



The Leader in Mixing Technology

MagMixer MBI

The New Standard for Cleanability,
Durability and Performance



MagMixer MBI

Superior cleanability, durability and performance

The LIGHTNIN MagMixer™ MBI sets the new standard for cleanability, durability and performance in food, pharmaceutical, biotech and personal care applications. Features include a dry-running Hyper-Flo™ bearing design, one-piece tank plate and flow-through channels, totally eliminating contamination concerns. These technologically-advanced mixers are fast-becoming the critic's choice for sanitary processing and storage applications – including plasma fractions, vaccines, injectables, media suspensions, buffer prep, cell culture and beverage blending.

Designed for Durability and Superior Performance

- Unlike sleeve bearings, the Hyper-Flo bearing **will not:**
 - fracture due to rough handling during mixer installation, removal or transport, or
 - fracture or generate particulates under heavy vortexing, a common phenomenon when magnetic mixers run at high speeds and low liquid levels.
- Suitable for up to 30,000 liters and viscosities up to 1,000 cp. (Viscosity limits depend on tank volume)
- Advanced three-blade impeller design increases flow by 30% for improved mixing.
- CE Marked.
- Comes with LIGHTNIN's 100% process guarantee.

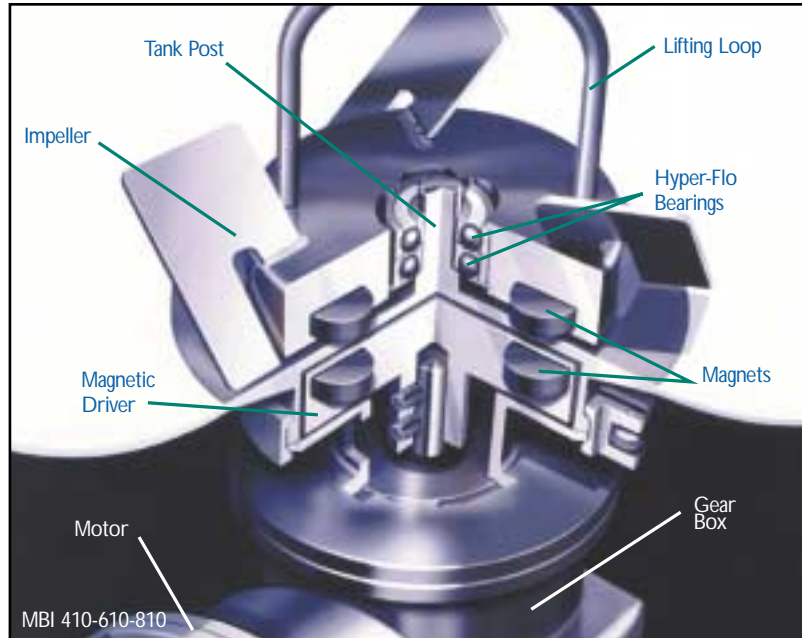

The patented Hyper-Flo bearing system is more cleanable and produces significantly less particulates than conventional sleeve bearing designs.

Designed for Easy Maintenance

- Integral lifting loop permits easy installation and removal of the impeller.
- Unlike sleeve bearings, which must be sent back to the factory for replacement, Hyper-Flo bearings can be replaced on-site using only a pair of snap-ring pliers.
- Motors and drive assemblies weigh from 25-50 lbs., depending on size, for easier handling.
- Speed reducer and motor attach to the tank plate with a Tri-Clamp* connection for simple attachment and detachment.
- Drive can be rotated through 360° for easy maintenance access and to minimize interference with other external tank components.
- Bottom-mounted design provides low center of gravity on mobile tanks for increased stability during transport.
- White epoxy paint finish is easy to clean.
- Alternate all stainless steel drive available for ultimate sanitation and corrosion resistance.
- Common spare parts and same bearing design used in all four sizes of MBI.
- Easily maintained on-site, in seconds.

MagMixer MBI 205

The LIGHTNIN MagMixer MBI 205 is the latest extension of the already popular MagMixer MBI family. This small footprint design further establishes the series for its benchmark cleanability, durability and performance in pharmaceutical and biotechnology applications. This exceptionally versatile mixer is suitable for solutions in open and closed tanks from 20 liters.

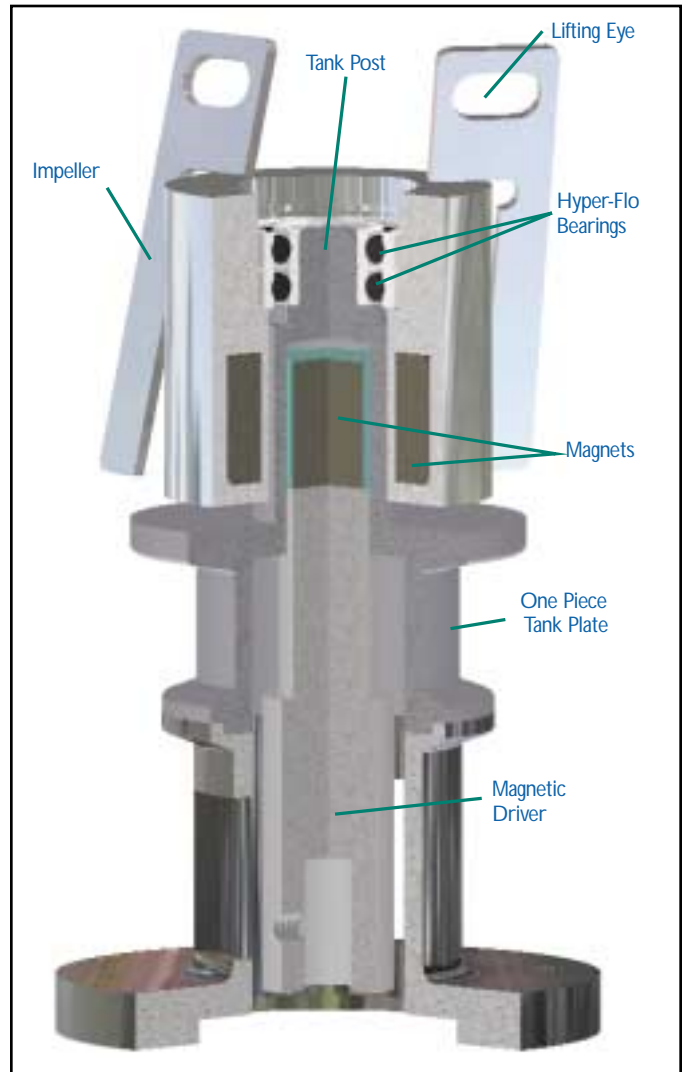

The MBI 205 provides the same process performance, ability to run dry, and process cleanability for small tank applications.

QAD for cGMP requirements, as standard

Easy to Validate - To demonstrate that FDA-mandated Good Manufacturing Practices (cGMP) guidelines have been met, you will receive a full Quality Assurance Documentation (QAD) package, including the LIGHTNIN Quality Plan, inspection test and data reports, materials of construction, weld procedures and polish verification data as standard when you purchase a LIGHTNIN MagMixer. In addition, Mill Certificates are supplied with each tank plate.

Specifications

Impeller

- 3 bladed 316L Stainless Steel
- Hyper-Flo™ bearing design
- 20 μ-inch Ra finish with EP standard (optional 10 μ-inch Ra finish with EP)

Tank Plate

- 316L SS one-piece tank plate
- Certificate of Compliance and Mill Certificate shipped with each tank plate
- Surface finish per customer specification (32 μ-inch Ra minimum)

Drive Assembly

- 1/3 - 1 HP
- Lightweight aluminum alloy IP56 reducer with integral motor
- Washdown duty drive, with FDA approved lubricant 1.25 AGMA SF
- Severe-duty washdown motor
- 316SS pedestal with Tri-Clamp* fitting
- Optional: 300-Series stainless steel drive available

Motor Options

- IP55 (washdown), 56C TEFC, Single-phase, 115V, 50 or 60 Hz, DC
- AC washdown duty, TENV stainless motor with inverter
- All stainless steel motor
- XP C&D inverter duty motor
- NEMA 4/12 SCR controller

Custom Options

- High alloy, non-ferrous tank plate and impeller
- Tank plates for jacketed vessels
- Tachometer
- White epoxy or stainless steel paint

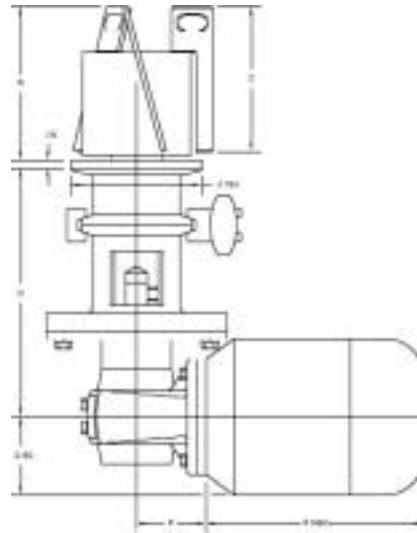

MagMixer MBI 205

Model	HP	A	B	C	D	E	F	AC Motor Option	DC Motor Option	Impeller Dia.	Tank Plate Dia.
MBI205	.33	3	3.5	3.3	6.3	2.4	8.4		F	13	3
5 : 1 ratio (nominal 350 rpm)											
<i>Dimensions in Inches</i>											

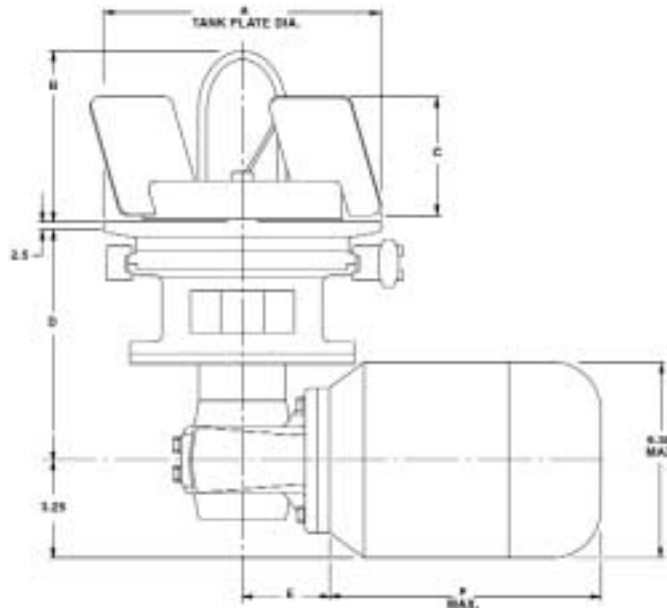

MagMixer MBI 410, 610 & 810

Model	HP	A	B	C	D	E	F	AC Motor Option	DC Motor Option	Impeller Dia.	Tank Plate Dia.
MBI410	.50	6	5	2.5	6.5	2.4	8.4		F	13	6
MBI610	.75	8	5.1	3.4	6.5	2.4	9.1		F	15	8
MBI810	1.0	11.75	5.2	3.9	7.2	2.4	9.1		F	16.5	11.75
9.25 : 1 ratio (nominal 175 rpm)											
<i>Dimensions in Inches</i>											

Cleaning To A Greater Degree...

The cleanability of LIGHTNIN's MagMixer MBI impeller is proven - validated both in factory acceptance tests and in actual process performance in hundreds of installations.



Independent third-party validation using proven CIP protocols from spray-only to full immersion.**

- European Hygienic Equipment Design Group Test Procedure, 2000
- Sprayball-only, Factory Acceptance Test (Pure-Flo Cotter), LIGHTNIN MBI 205 MagMixer
- Sprayball-only, Factory Acceptance Test (Martin Petersen Co.), LIGHTNIN MBI 610 MagMixer
- Soil Contaminant Removal, LIGHTNIN MBI 610 versus competitive mixer, using an immersion protocol (Silliker Laboratories)
- Soil Contaminant Removal, LIGHTNIN MBI 410 versus LIGHTNIN MBH 410, using an immersion protocol (Silliker Laboratories)

Designed for Maximum Cleanability

- The patented Hyper-Flo™ bearing design has been proven more cleanable than sleeve bearing designs. Independent tests comparing the new MagMixer MBI to an older design and the leading competitive product concluded that the MagMixer MBI is easier to clean, especially in applications involving sticky, hard-to-clean soils.**
- Can be Cleaned in Place (CIP) using spray-only or immersion protocols.

- Can be run dry to permit complete draining during CIP cycles.
- Impeller assembly can be autoclaved – magnets designed to withstand temperatures up to 300° F.
- Bearings can be removed easily for Cleaning Out of Place (COP) or maintenance.

Designed to Prevent Contamination

- The Hyper-Flo bearing has rolling contact points, resulting in significantly reduced particulate generation. Independent testing confirmed that particulate generation from the MagMixer MBI is below the limits set by the USP standard for particulate generation in large-volume injectables.**
- All in-tank materials meet USP Class VI biotech standards for injectables.
- The Hyper-Flo bearings are constructed with MP35N Surgical Steel races, silicon nitride balls, and GFT bearing cages (optional 316L Stainless Steel bearing cage construction available) for corrosion resistance, strength and bio-compatibility.



MBI 410-610-810

LIGHTNIN FOR SERVICE

Lightnin Process Equipment Services (LPES): The Fastest Route To Uptime.

Expertise: LPES technicians are the backbone of our dedicated service organization. They're uniquely qualified to keep your LIGHTNIN mixers running right.

Lightnin Certified Technicians: All LPES technicians are certified via training courses to ensure that the work they do meets the highest standards for consistency and reliability.

Genuine LIGHTNIN Parts: All LPES repairs follow original design specs and use only factory-authorized replacement parts.

Full LIGHTNIN Factory Warranty: We're so confident we'll do the job right that all LPES repair and service work is covered by a full factory warranty. What we repair, we guarantee – 100%.

Additional LPES Services: LPES offers programs that are customized to meet the needs of each individual customer. This expertise extends to all mixer manufacturers. In fact, no other single source can provide the depth or breadth of support to help you achieve your productivity and cost-reduction goals. LPES offers the following service programs that focus on your business solutions:

- **Installation and Start-up**
 - Installation Management
 - Commissioning Services
 - Process Services, On-Site Support or Lab Modeling
- **Maintenance and Repair**
 - Preventive, Predictive and Emergency
 - Field/In-house Repair
 - Exchanges
 - Extended Warranties
- **Asset Management**
 - Equipment Audit
 - Parts Inventory Audit
 - Inventory Reduction Services
 - Equipment Upgrades
 - Extended Storage



Call the LIGHTNIN Experts

For more information about LIGHTNIN's MagMixers or to discuss your application, contact your local LIGHTNIN Sales Representative. Or visit our website at www.lightninmixers.com.

Or call 1-888-MIX-BEST (U.S. and Canada), or 1(585) 527-1623 (worldwide).

*Tri-Clamp is a registered trademark of Tri-Clover, Inc.

**Copies of the reports are available from your LIGHTNIN Sales Representative or on our website at www.lightninmixers.com.

The LIGHTNIN trademark is registered in the U.S. and other countries.

MagMixer is a trademark of LIGHTNIN.

B-913-L-1-03

LIGHTNIN

*When it comes to mixing better
We never stop*

135 Mt. Read Blvd.
Rochester, NY 14611 USA
www.lightninmixers.com